

Installation Instructions

Tools Required:

Screwdrivers

Small Straight (Flat Blade) - for Terminal Block wiring

#2 Phillips (Crosspoint) - for various #8, #10, and #14 screws

Wrenches / Sockets

7/16" - for #1/4-20 Hex Head bolts attaching header to jambs

1/2" (13mm) - for #5/16 Hex Head bolts attaching end stops and operator parts

15/16" wrench - for carrier and anti-rise roller adjustment

Allen Wrenches

3mm - for "SX" & "SO" roller catch adjustment

1/8" - for "SO" arm stop & "SX" bottom pivot

5/32" - for "SO" top pivot

5mm (3/16") - for "SO" arm pivot screw

7/32" - for "SX" breakout adjustment

5/16" - for carrier and anti-rise roller adjustment

Electric Drill with the following drill bits -

9/64"(or #28) - for installing sensors & "SO" bottom roller stop

5/32" (or #22) - for installing #10 sheet metal screws into adjacent storefront

13/64" (or #7) - for installing #14 sheet metal screws into adjacent storefront

1/4" - for clearance holes in jambs

Impact Drill with the following masonry bits -

1/4" - for #10 screw anchors

5/16" - for #14 screw anchors

Level - suggested 4' minimum

Step Ladder - 4' or 6'

Tape Measure

Caulking and Application Gun

Electrical Wire Strippers /Cutters - for sensor wiring

Grease [to hold "SX" bottom guide block on shaft]

BEA Universal Remote Control - for adjusting sensors

Suggested Fasteners Required - (Not supplied)

Jamb Attachment Screws -

#14 X 2-1/2" PHSMS (Pocket Jambs)

#14 X 3" FHSMS (Tube Jambs)

Optional Anchors for masonry

Threshold Attachment Screws

#10 X 1-1/2" FHSMS

Optional Anchors for masonry

Header Attachment Screws

#14 X 1-1/2" HHSMS

#14 Flat Washer

Construction Shims - for squaring door frame in o

pening

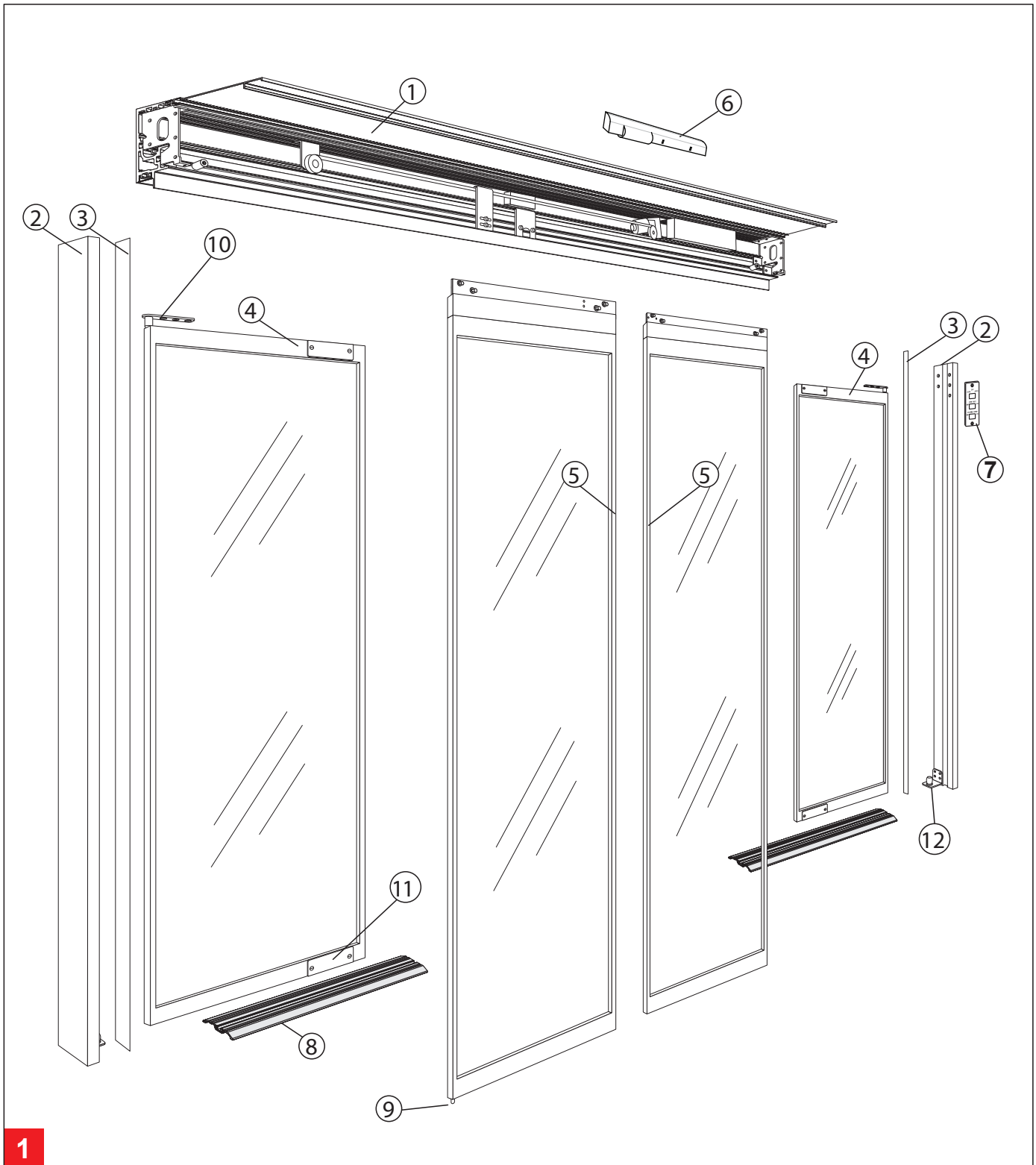

1

Components - Overview

- | | | |
|------------------------------|-----------------|-----------------|
| ① Operator Unit | ⑤ Sliding Panel | ⑨ Floor Guide |
| ② End Tube (Jamb) Extrusions | ⑥ Sensor | ⑩ Bearing Pivot |
| ③ Cover Extrusion | ⑦ Program-Panel | ⑪ Latch Device |
| ④ Sidelight | ⑧ Floor Rail | ⑫ Bearing Pivot |

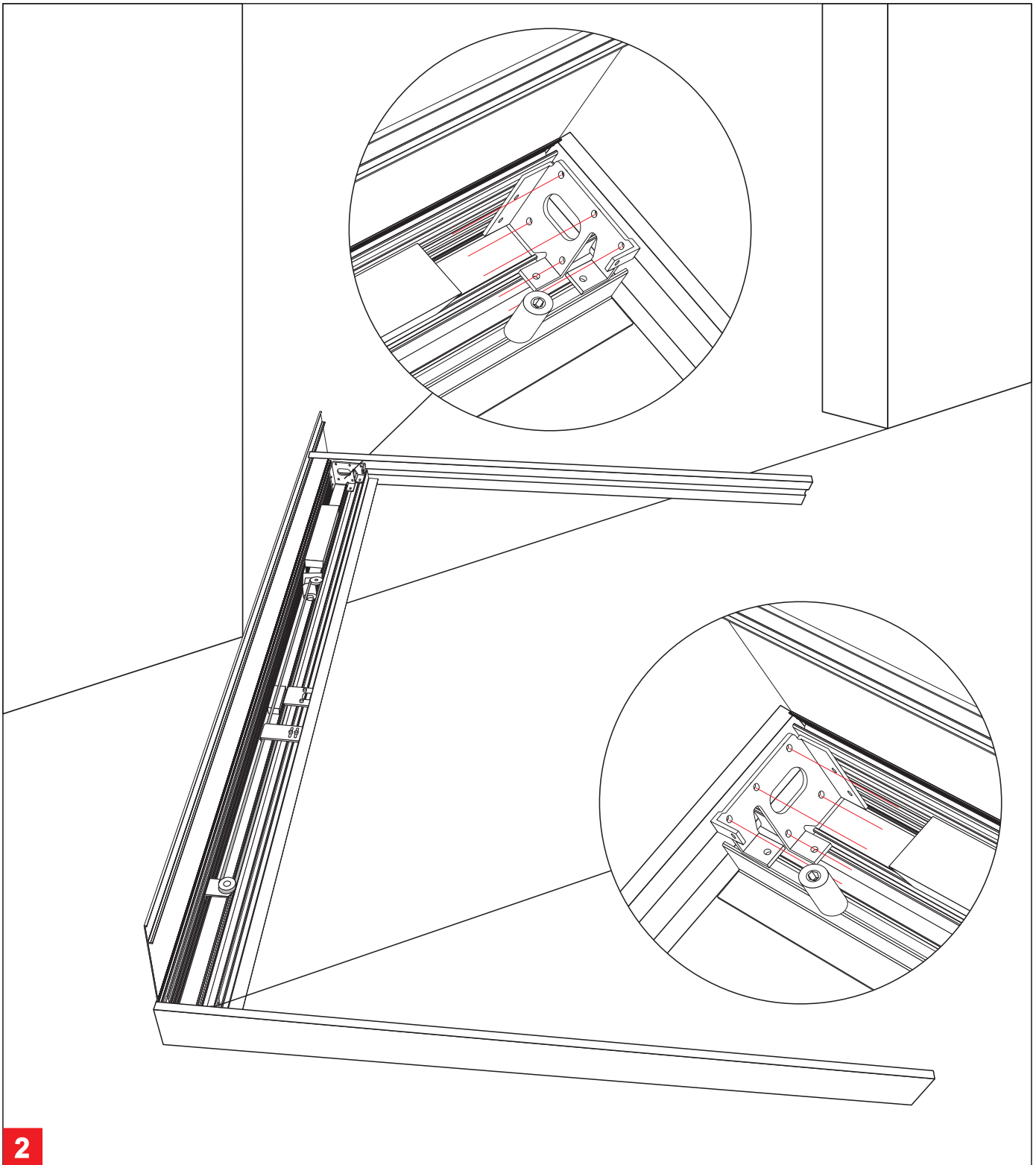

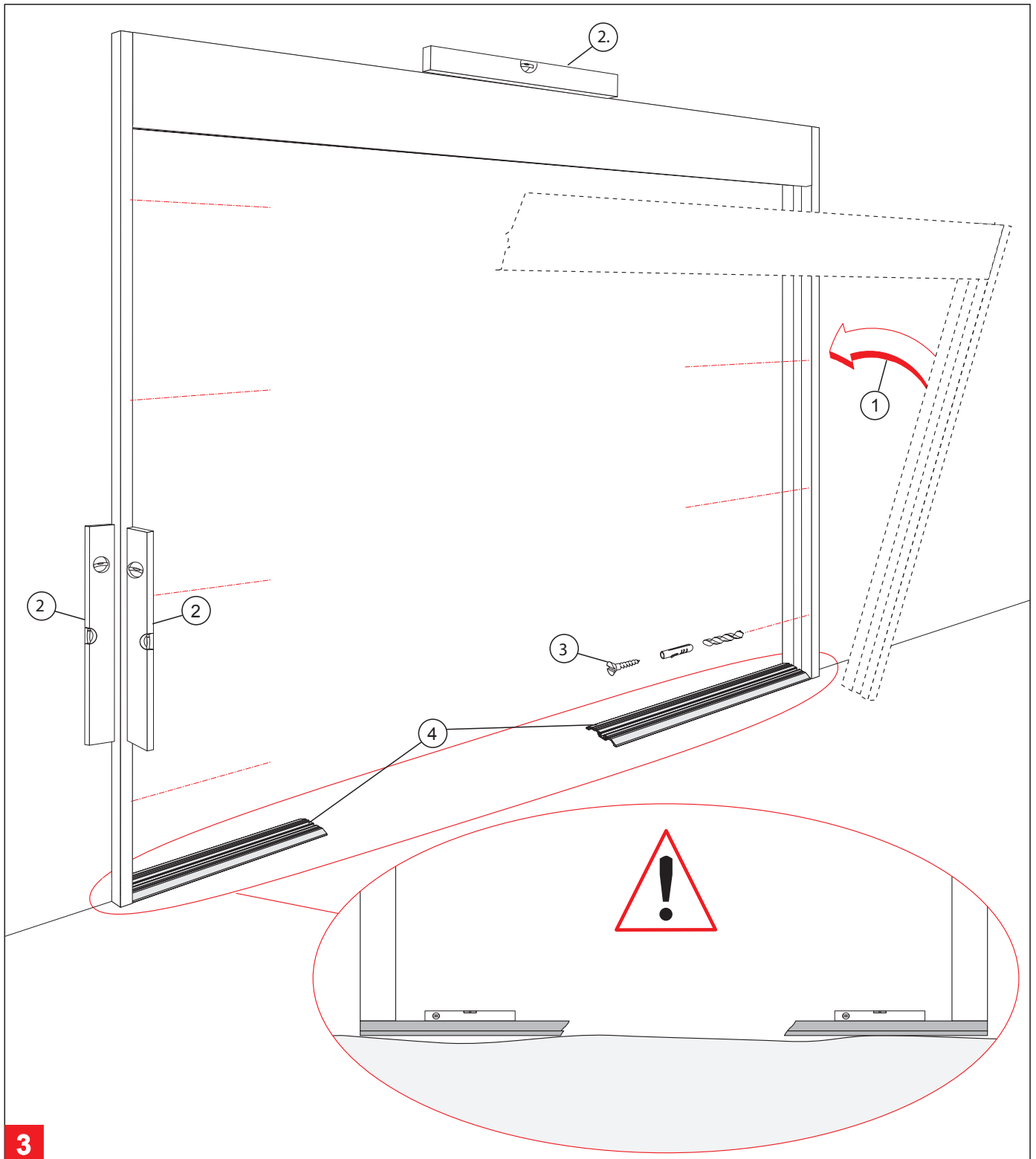

Header to Jamb Assembly

Fasten the header unit to the jambs using (5) 1/4-20 x 1" hex bolts per side. (7/16" socket/wrench required.)



3

Assembly

- ① Place the header & jamb assembly into the rough opening.  The mounting of the operator to the rough opening must meet applicable building codes and standards.
 - ② Level all sides and shim as required.
 - ③ Fasten assembly into rough opening, after verifying unit is level and plumb in all directions.
 - ④ Place floor track in position.
-  Find highest floor elevation and shim accordingly.

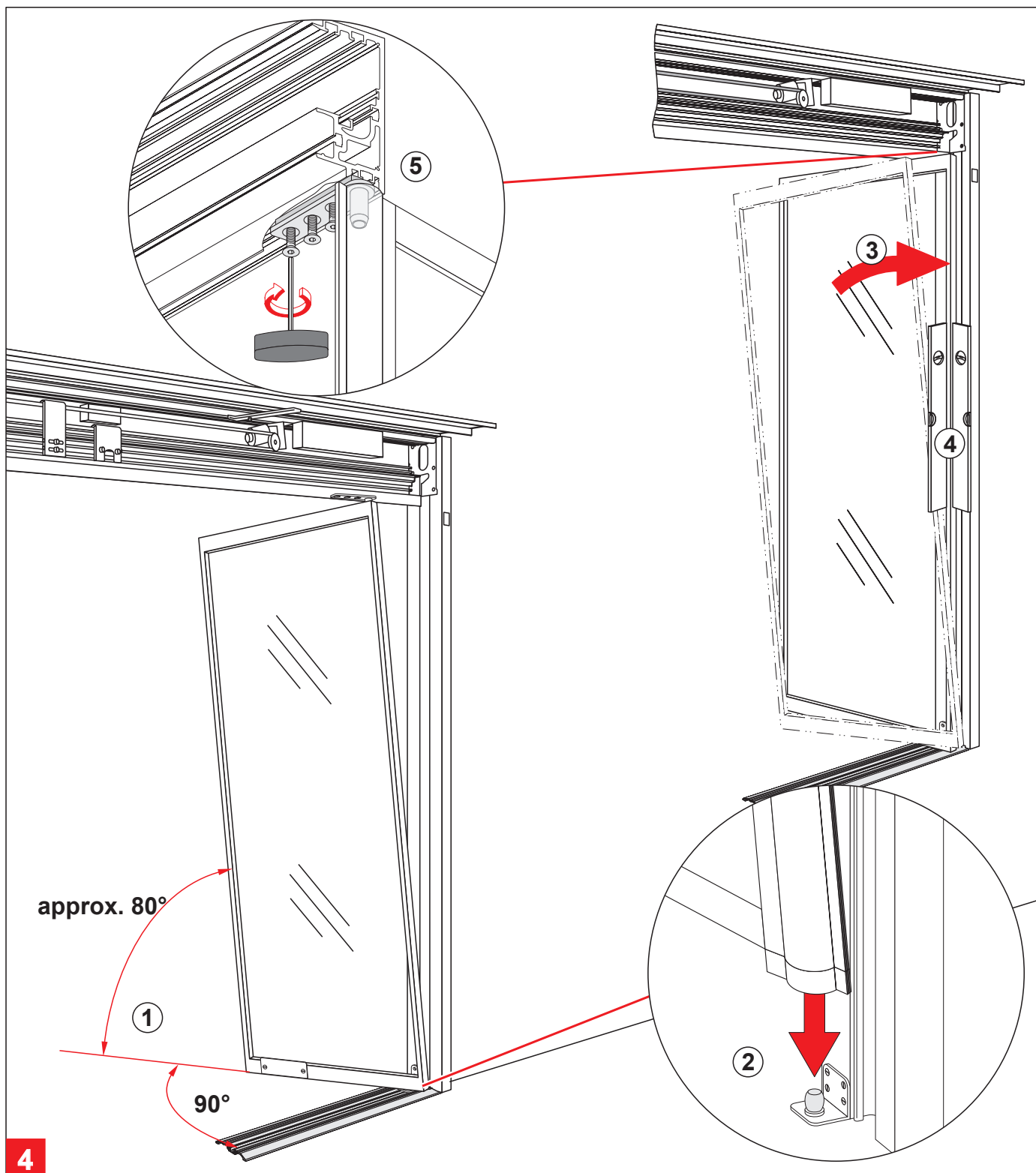

Sidelight mounting

- ①-② Align "SO" panel 90° to the "SX" track and 80° to the vertical jamb. Place "SO" panel onto bottom pivot mounted on the jamb.
- ③ Push "SO" Panel vertically to align with jamb. Rotate upper "SO" arm and lightly fasten to screw plate located in header.
- ④ Align and plumb "SO" Panel.
- ⑤ Tighten (3) 1/4-20 x 5/8 fasteners in "SO" top pivot, securing "SO" Panel to header using 5/32" Allen wrench.

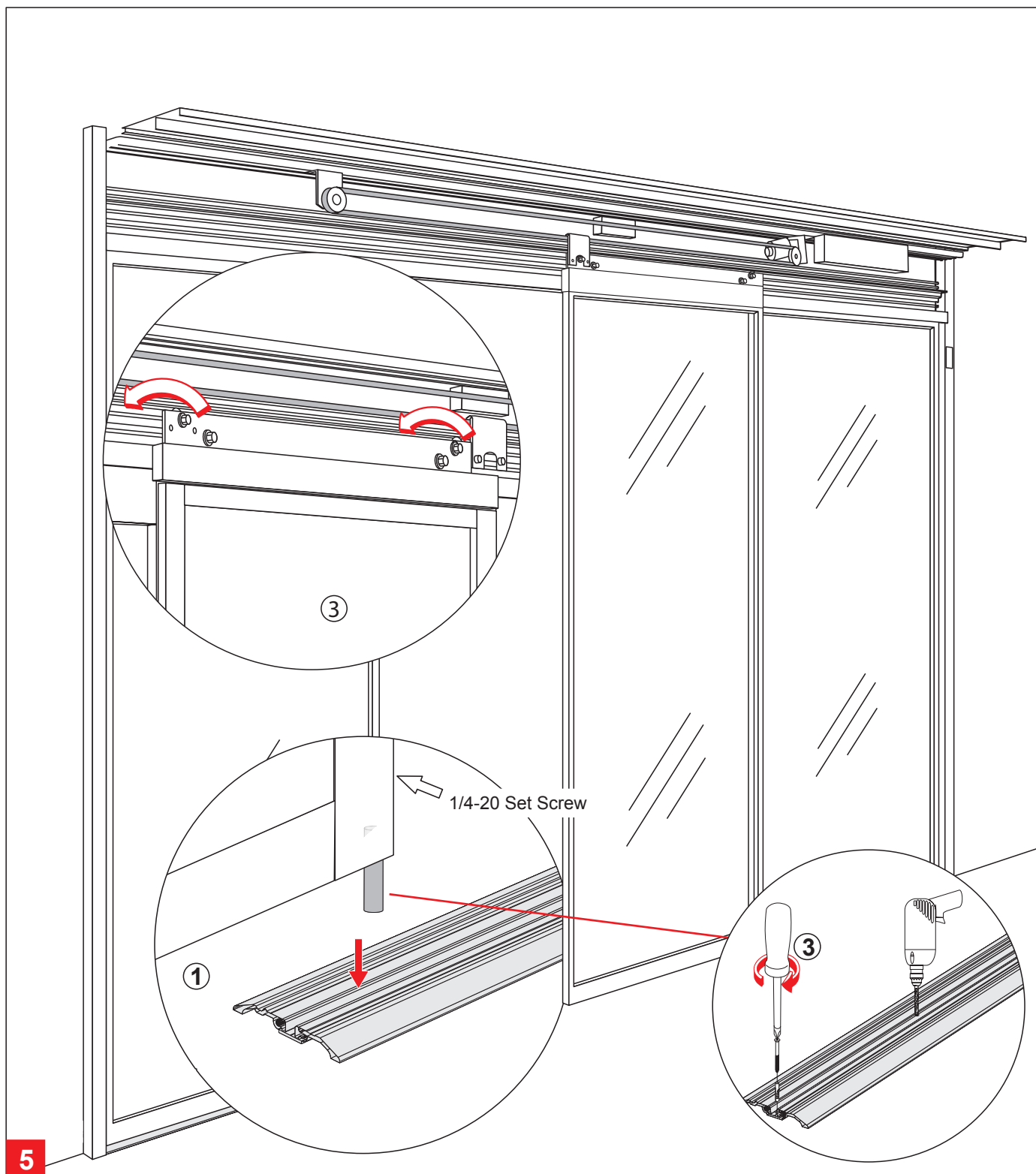

5 Hanging the “SX” panel

- ① Lift “SX” panel and place rollers onto roller track in header.
- ② Find the highest spot along track. Place small screwdriver below “SX” pivot, loosen set screw and re-tighten when “SX” bottom guide pin reaches screwdriver (1/8” Allen wrench required).
- ③ Align track with jamb. Fasten and anchor bottom track to floor.

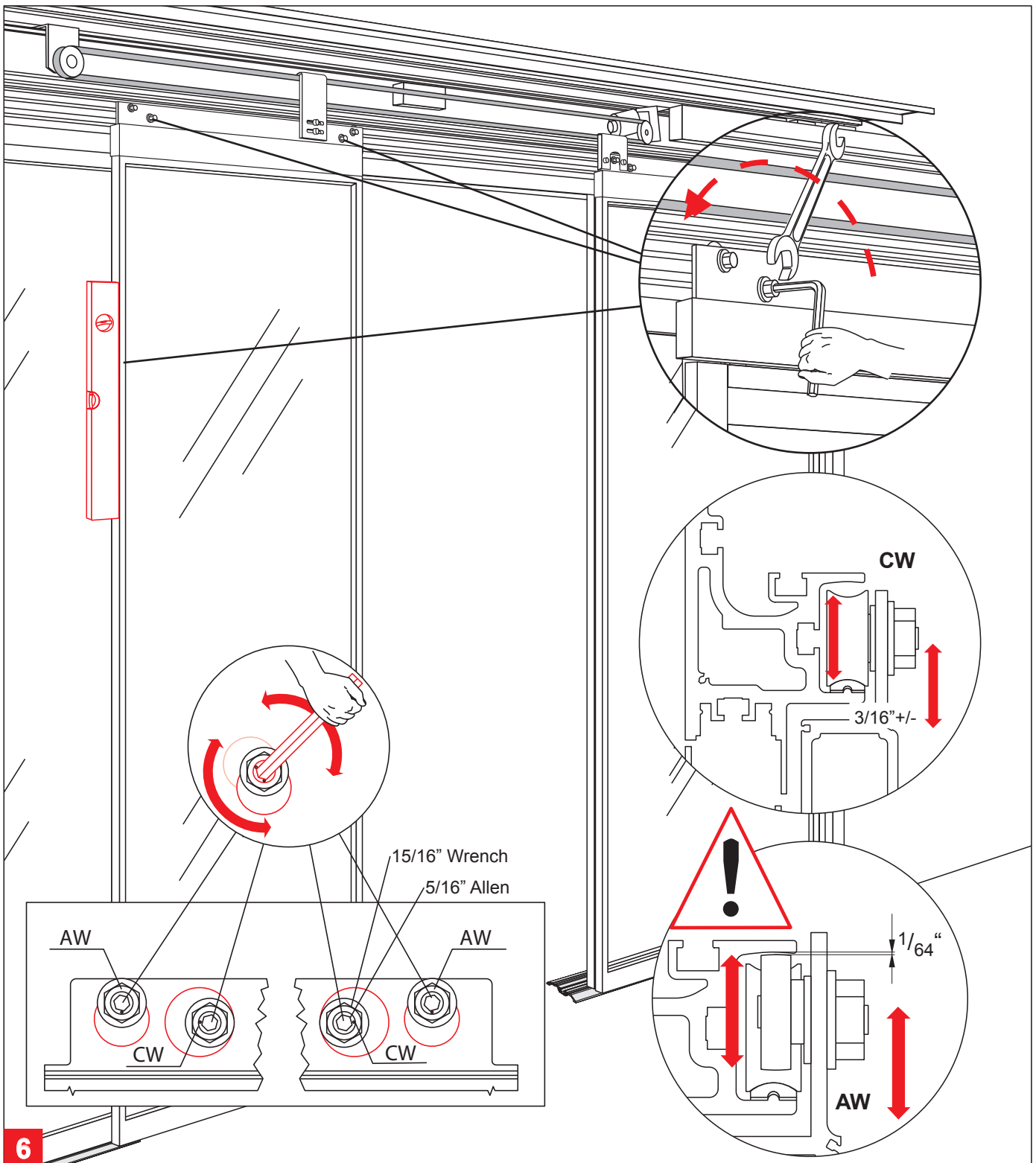

6

Vertical Alignment for SX panel

Using the eccentric carrier wheel (CW), and the anti-riser wheel (AW), level the sliding panel. Tighten hex nuts to secure the adjustment.

Adjustment of the anti-riser roller:

The anti-riser roller should not contact the top track anywhere along the slide path of the door.

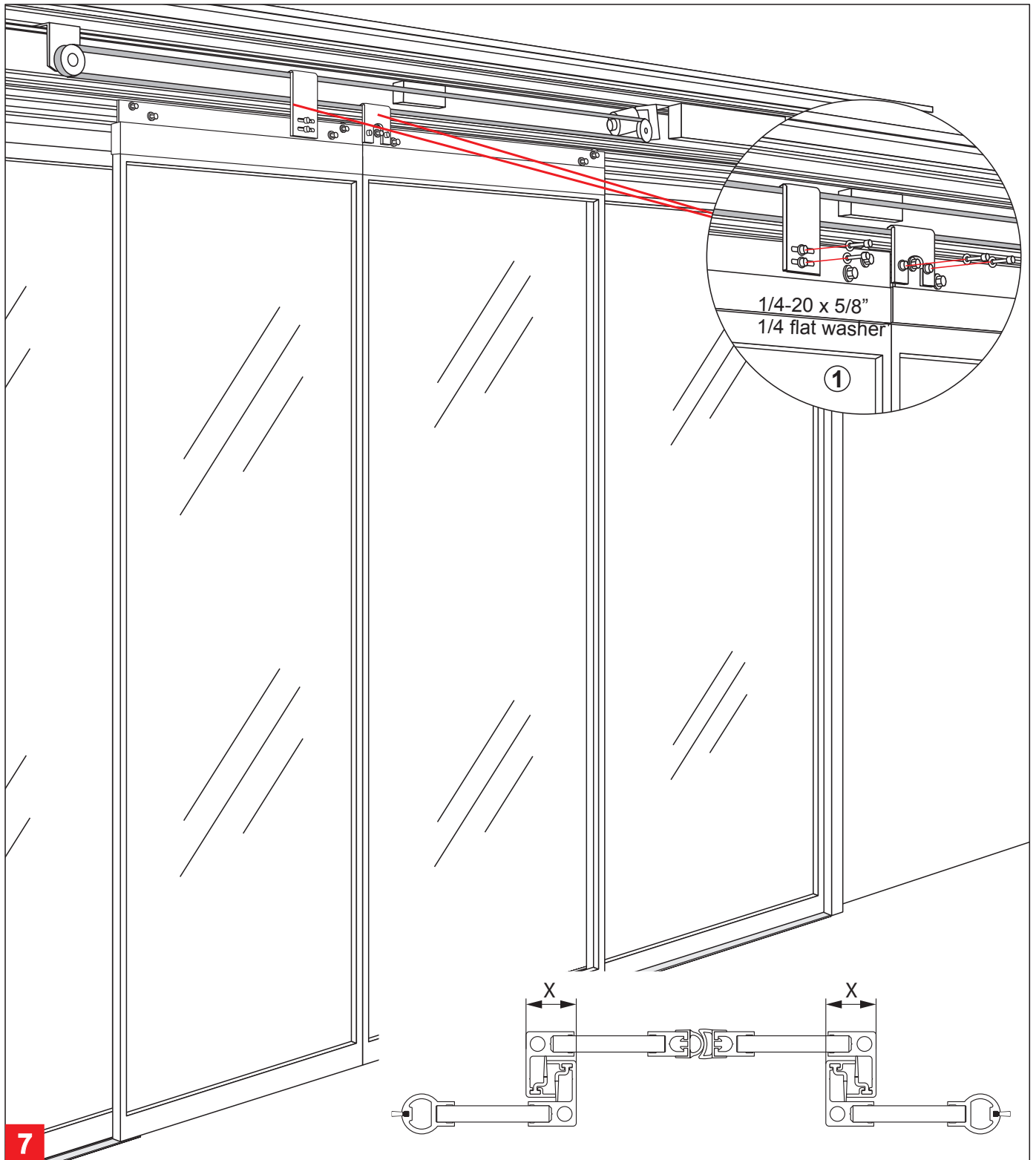

SX Panel Centerline Adjustment

- ① With the lower belt bracket securely fastened and the upper belt bracket in its loose position, the "SX" panels can be properly adjusted to their center position. After panels are centered, fasten upper belt bracket to carrier. (7/16" socket or wrench required.)

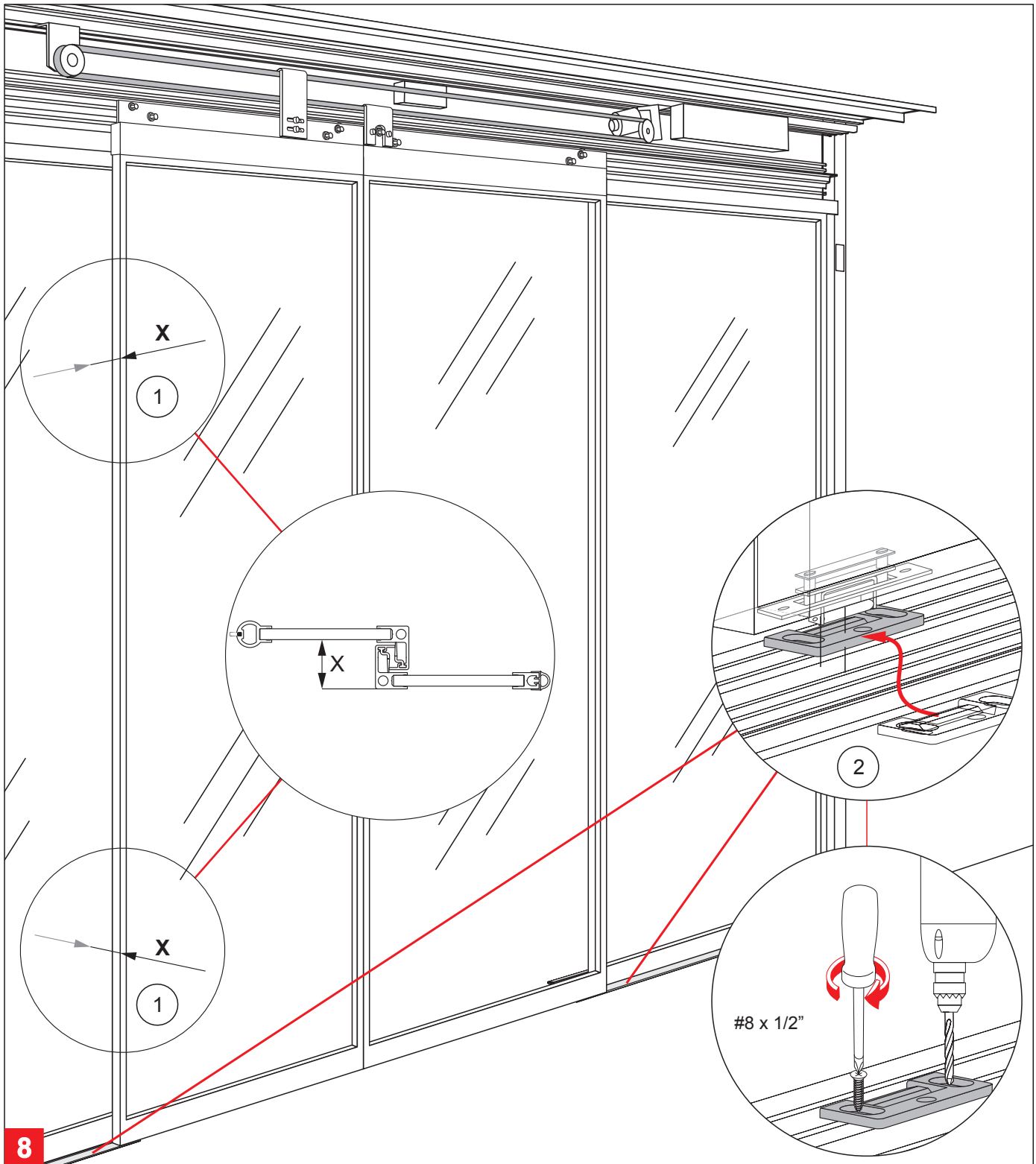

SO Panel Adjustments (For Recessed Applications Only)

- ① Adjust SO panel to be parallel to the "SX" panel from top to bottom.
- ② Correctly place "SO" bottom latch stop on floor track and fasten with (2) countersunk screws in latch slots.
(Phillips screwdriver required.)
- ③ Check "SO" panel position and adjust if necessary.
- ④ Anchor "SO" bottom latch stop with remaining countersunk screw.

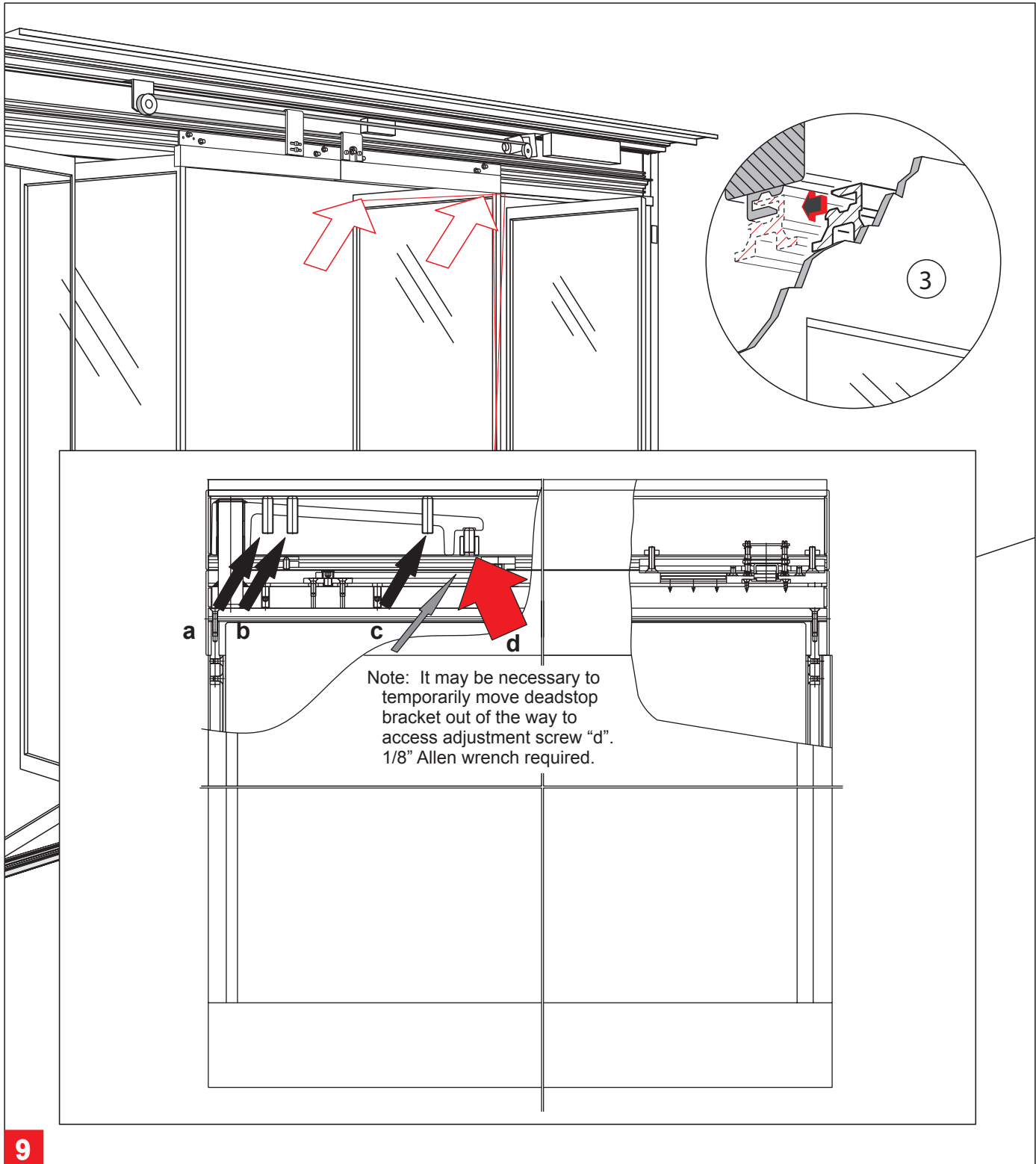

9 Adjustment of the Breakout-Unit

1. Loosen the set screws (a, b & c) to prevent interference while adjusting door. (7/32" Allen wrench required.)
2. Use the adjustment screw (d) to lift (CW), or lower (CCW), the leading edge of door.
3. Continue adjustment until the re-latch profiles are properly aligned.
4. Tighten all set screws (a, b & c) until tight and secure.

Recheck the latched position alignment and readjust as necessary.

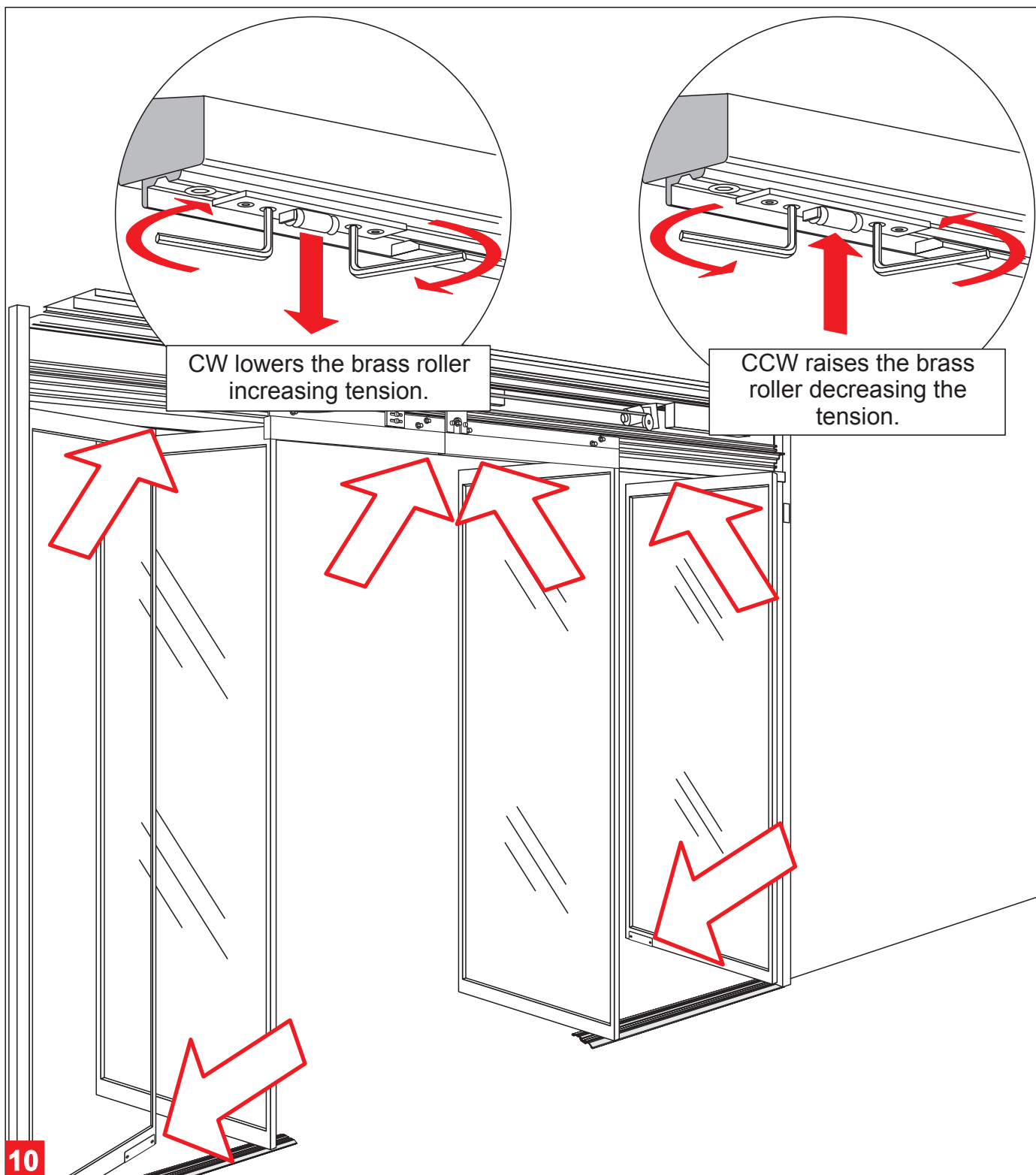

Adjustment of the Roller Catch

Align the roller catches as illustrated, using the adjustment screws. (3mm Allen wrench tool required.)

Pay close attention to the disengagement, or breakout force.

Do not exceed ANSI A156.10 Standards.

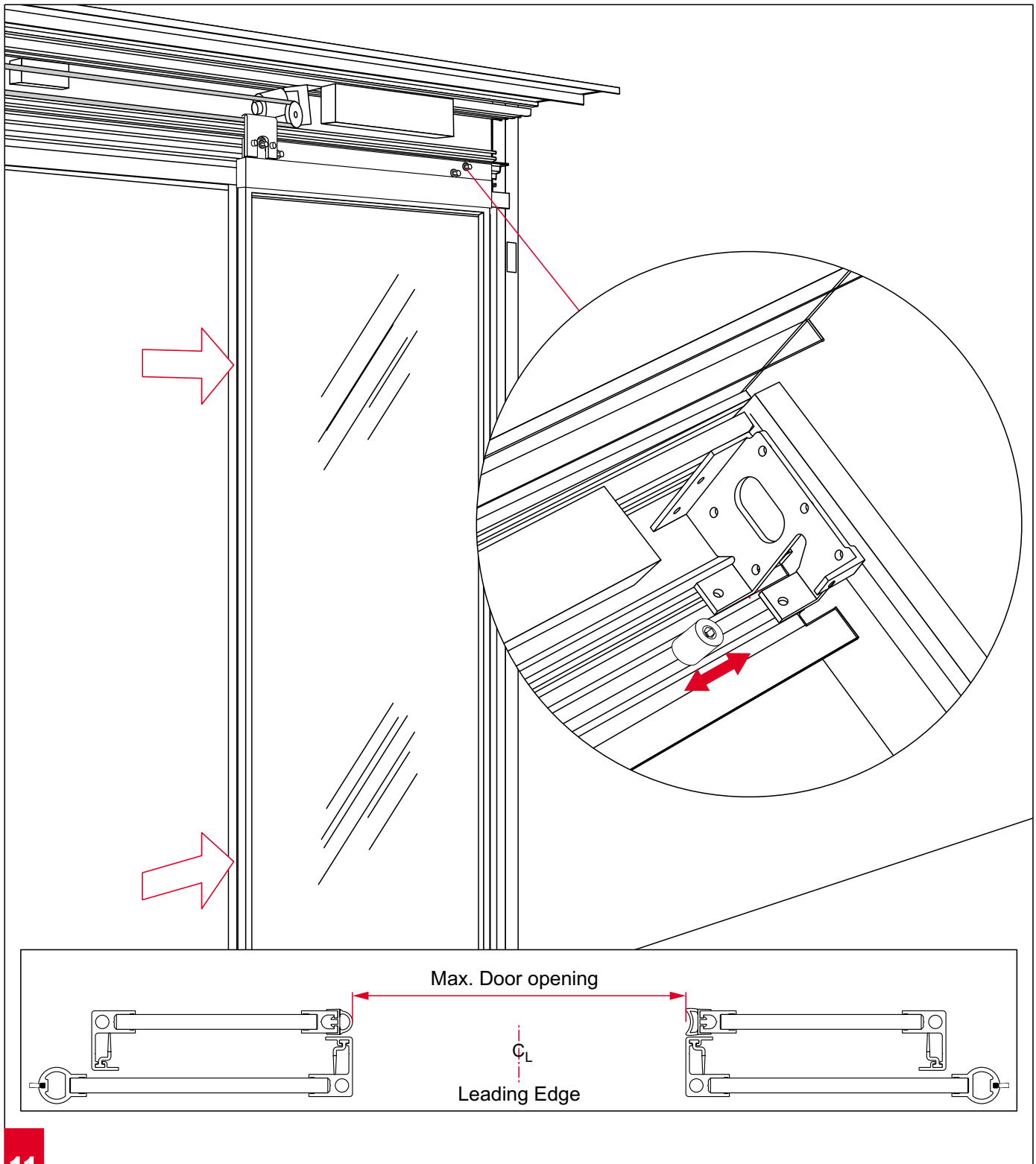

Adjustment of the End Stops

End stops are installed at the factory. Adjustments should be made by loosening the bolt and sliding the stop to the appropriate position. Be sure adjustments are made symmetrically to the door opening, while providing proper finger safety per ANSIA156.10 Standards. (1/2" socket or wrench required.)

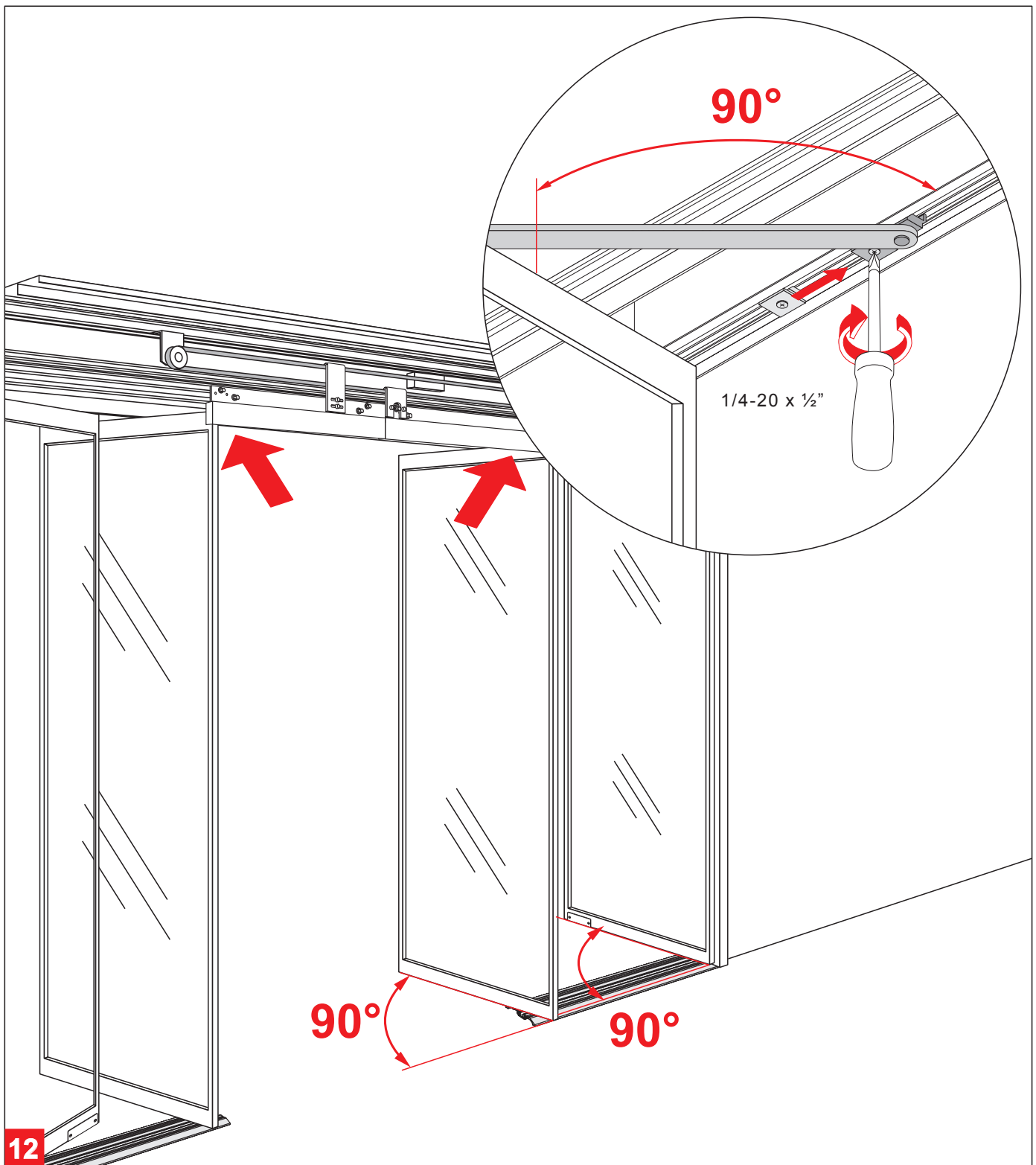

12

“SX” and “SO” Panel Breakout Adjustment

1. Open “SX” & “SO” panels to 90°.
2. Move arm stop blocks to engage arm. (1/8” Allen wrench required.)
3. Secure stop blocks.

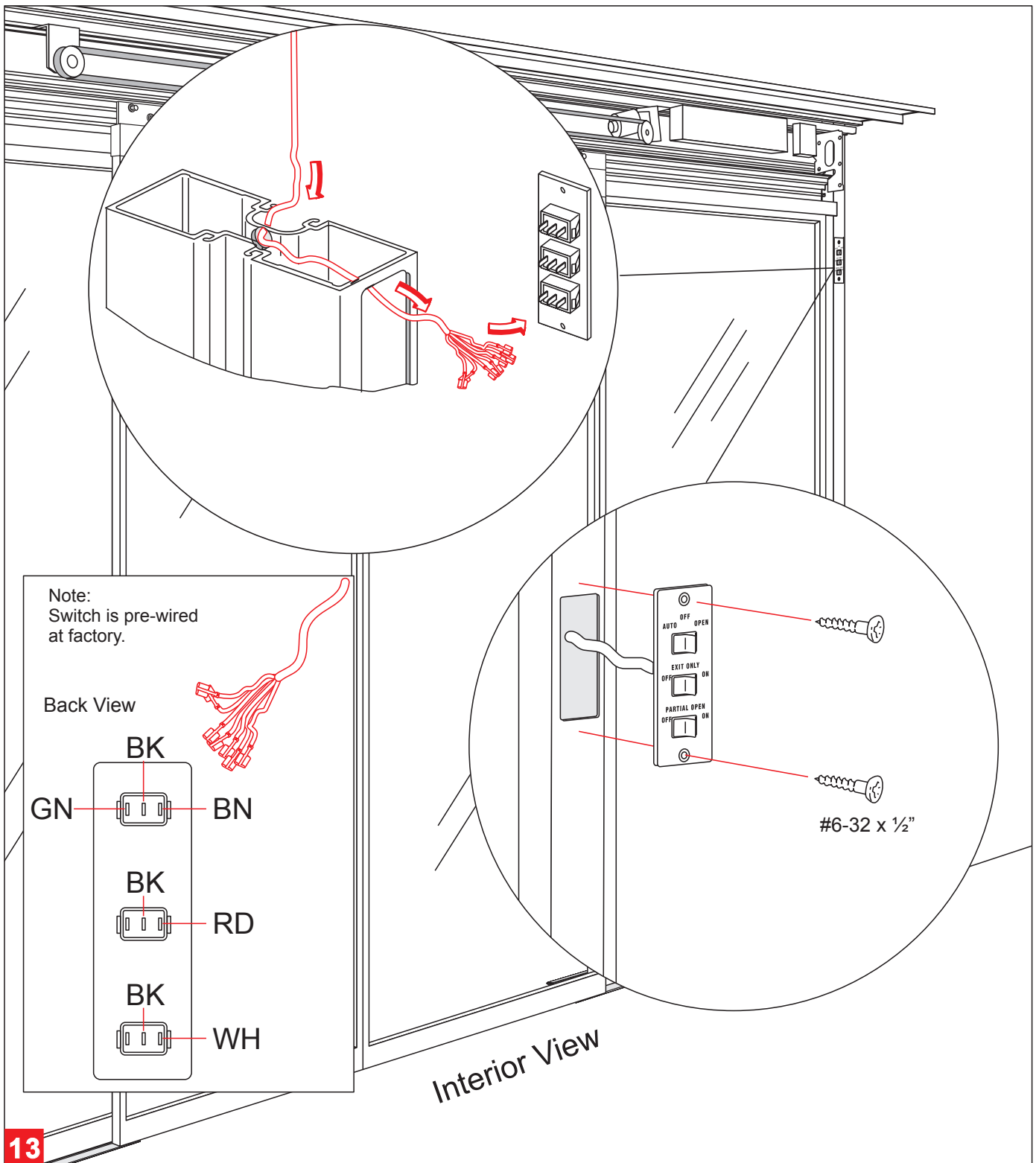

13

Mounting of Program Panel and Routing of Cable

Route cable as illustrated.

Insert program panel as illustrated, and fasten into place using Phillips screwdriver.

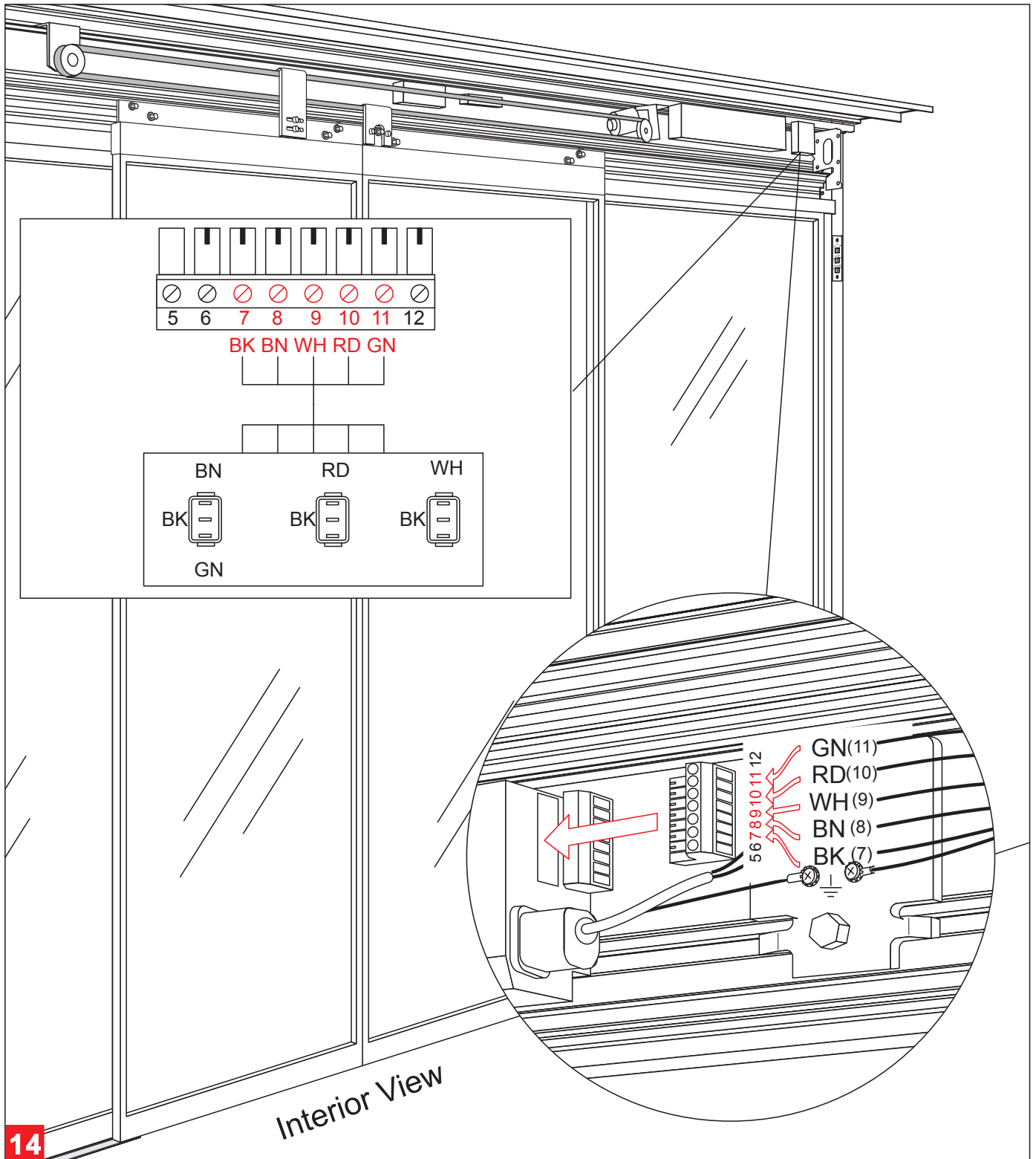

14

Electrical Termination of Program Panel

Connect program panel as illustrated.

The cord should not be: Routed through doorways, window openings, walls, ceilings, floors, or the like; attached or otherwise secured to the building structure, or concealed behind walls and the like.

ESA-400 Fine Frame

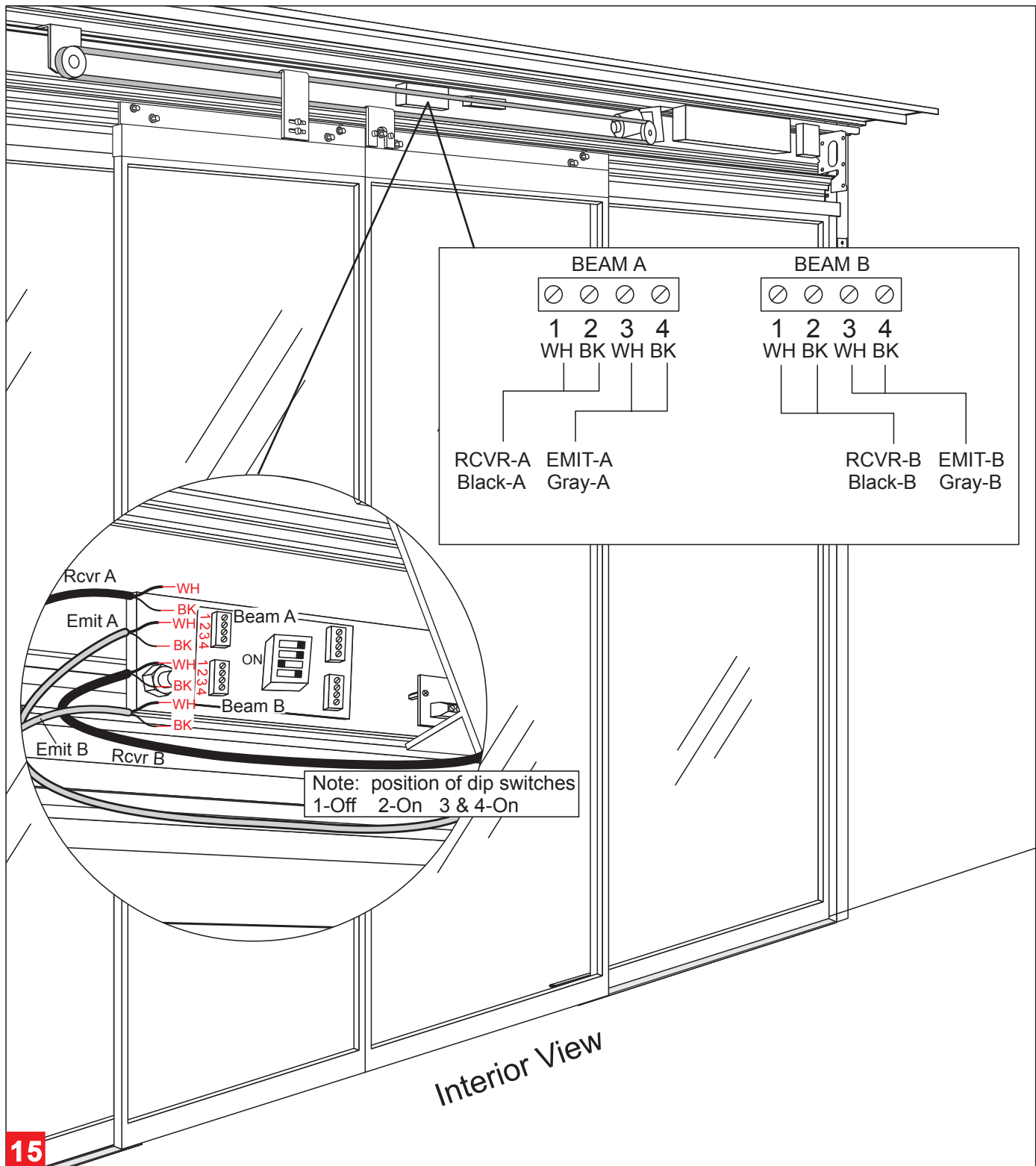

15

Wiring of Safety Beams (See Appendix 1 for more details)

Connect BEA Microcell 3D monitored safety beams as illustrated.

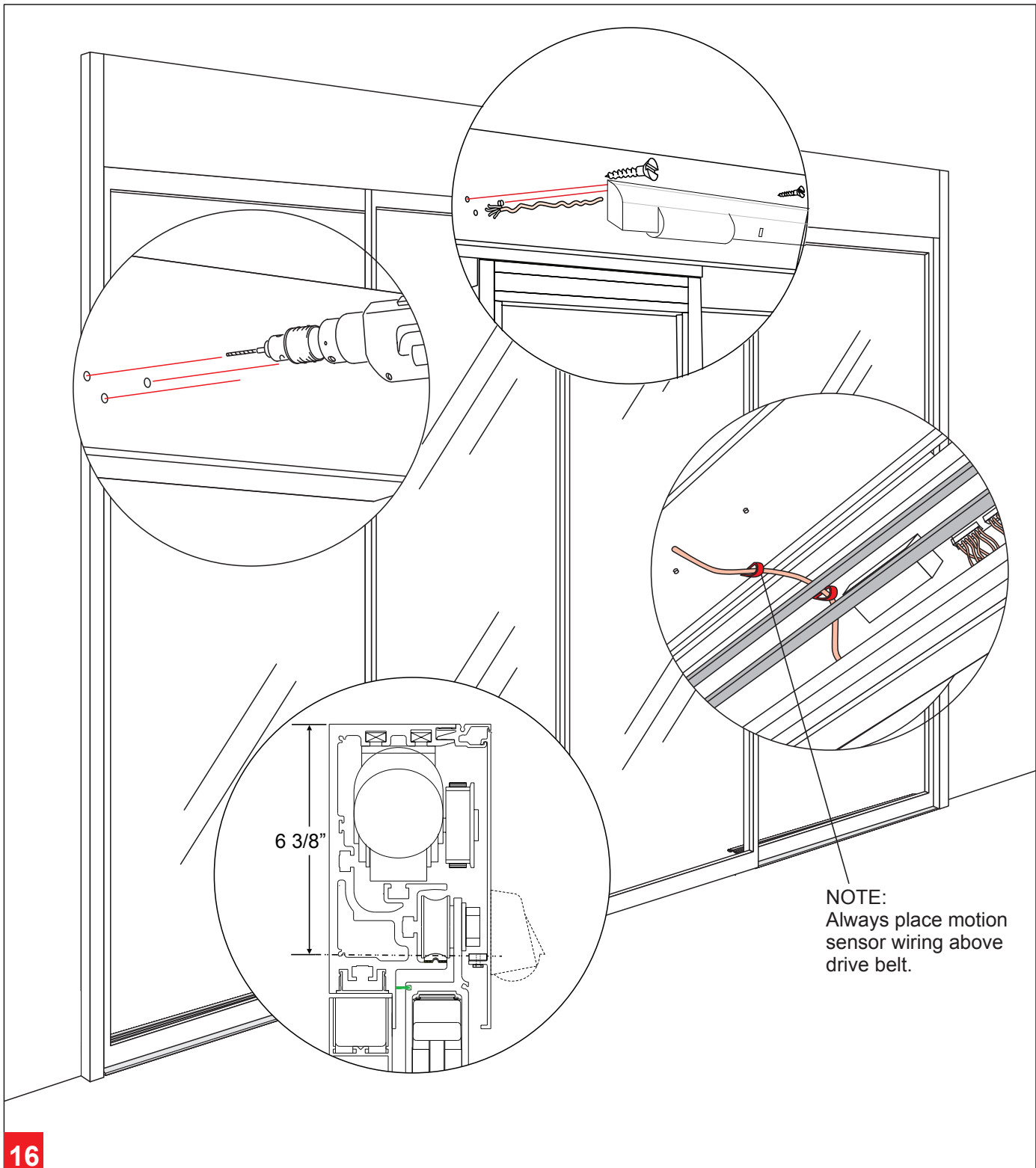

16

Mounting of Motion Sensor (See Appendix 2 for more details)

Mount the sensor as illustrated.

Caution: Be careful when drilling for sensor attachments so as not to damage internal wiring.
Note: Recommended mounting locations may not work in all door configurations.

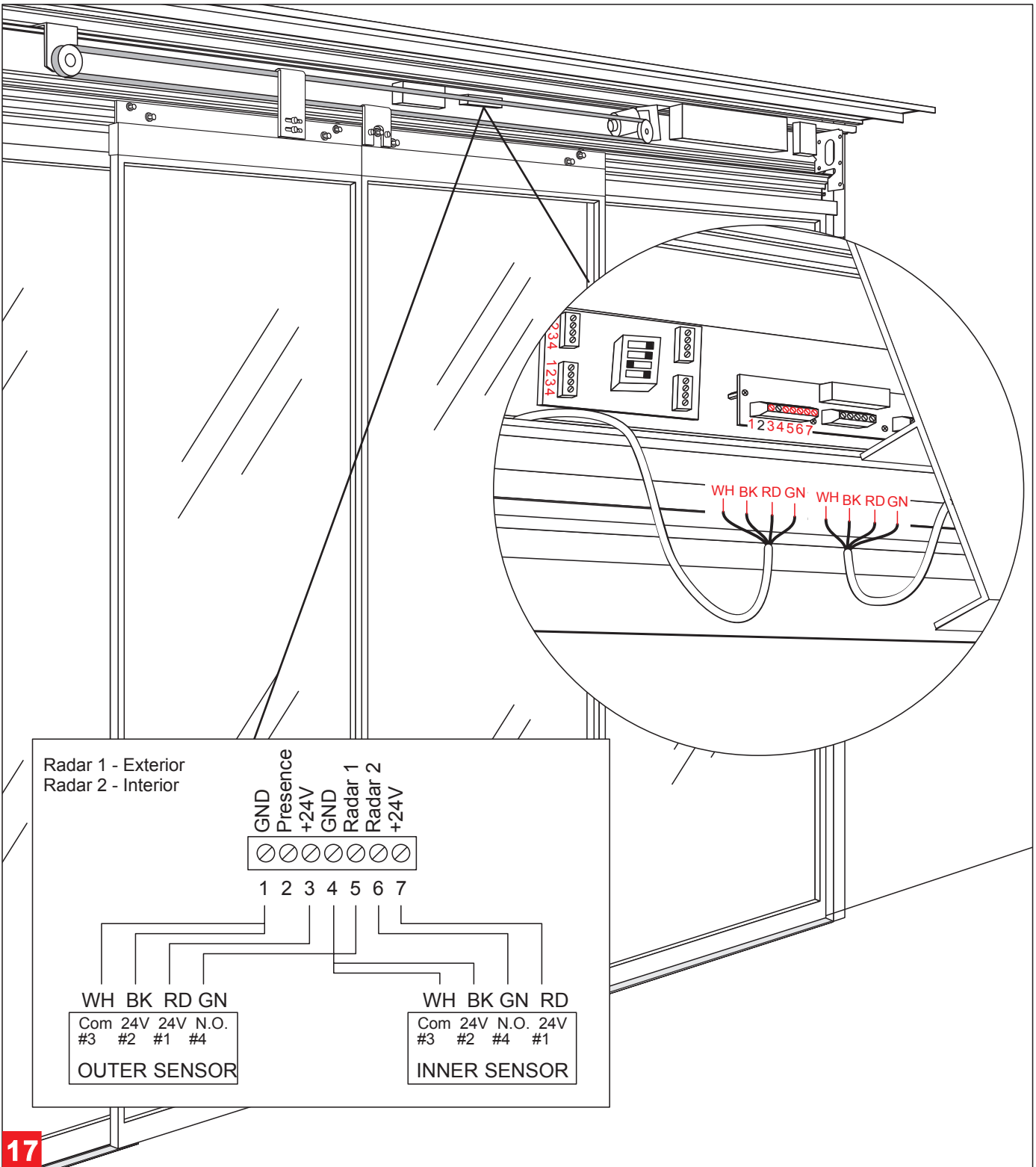

17

Wiring of the Motion Sensors (See Appendix 2 for more details)

Connect the motion detector body as follows: #1-RED (24v), #2-BLACK (24v), #3-WHITE (Common), #4-GREEN (N.O.).

Connect the motion sensors to the interface board according to the wiring diagram.

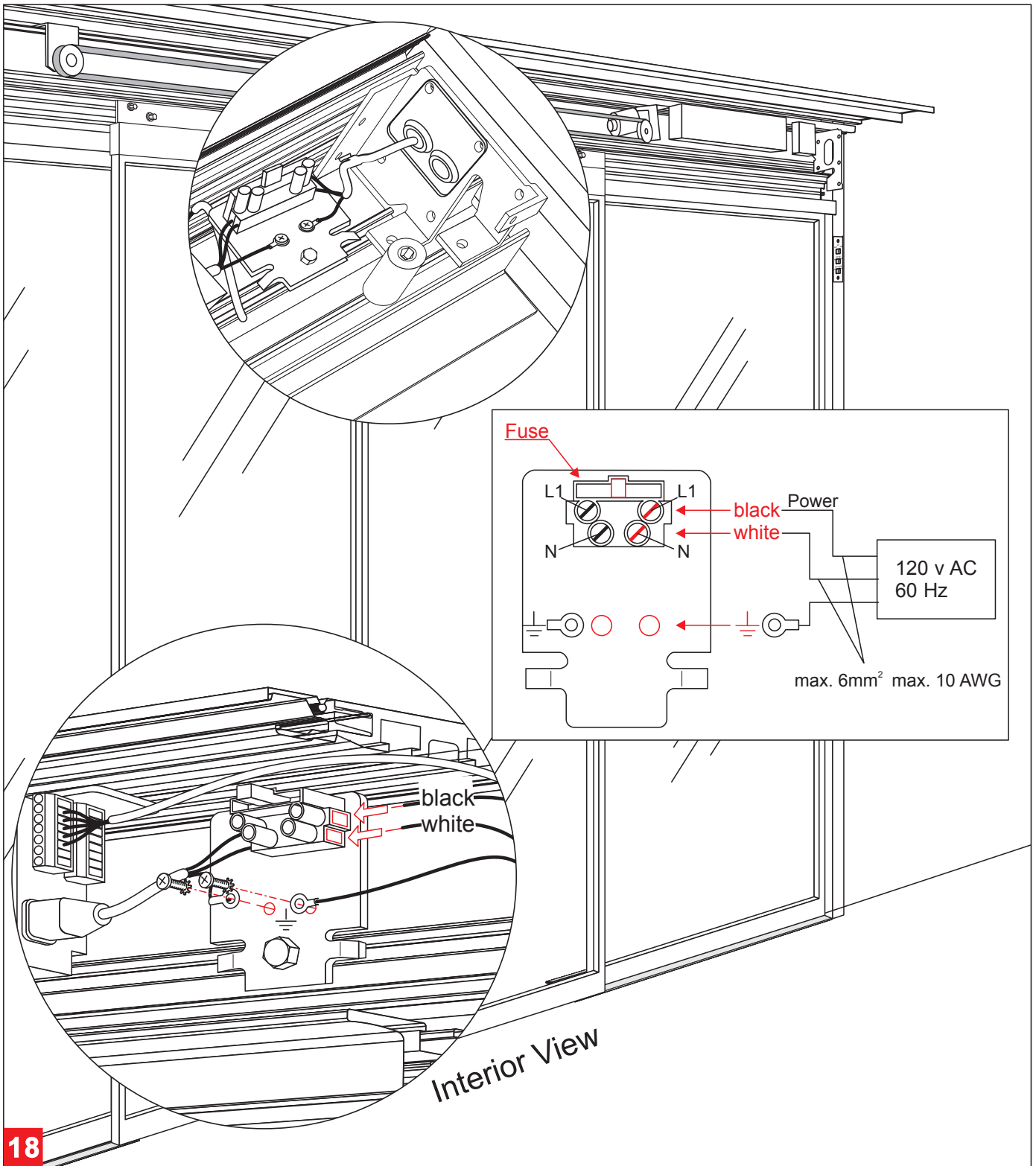

18

Overload Circuit / Line Power Connection

Connect the line power as illustrated.

Fuse: Use only T2A/120VAC (5mm x 20mm)

Use only Copper conductors.

ESA-400 Fine Frame



Input Voltage	120 VAC / 60 Hz +/- 10%
Line Fuse	2A (5mm x 20mm)
Power Supply for external devices	24 V DC / 2 A
Power consumption maximum standby	150 W, Peak 255W for 2 seconds 25 W
Average Power consumption	45 W/hour
Ambient Temperature	70° F

Program - Inputs	
OFF	
AUTOMATIC	
HOLD OPEN	
PARTIAL OPENING	
EXIT	

Data and Features	
Opening width, single panel	OW/2 -10% max 47 inch
Opening width, double panel	OW/2 -10% max 84 inch
Door weight, single panel	220 lbs (100 kilos)
Door weight, double panel	2 x 190 lbs (86 kilos)

Hand Terminal Adjustments	Factory Default	Performance Range	
		Minimum	Maximum
Opening Speed	75 %	3.8 in/sec	22.3 in/sec
Closing Speed	100 %	3.8 in/sec	11.0 in/sec
Crawl Speed OPEN	50 %		
Crawl Speed CLOSE	50 %		
Brake Rate OPEN	50 %		
Brake Rate CLOSE	50 %		
Brake Rate Reverse	80 %		
Hold Open Time	1 sec	1 sec	60 sec
Partial Open Distance	52%	9.875"	Full Open
Hold Open Time Night / Bank	10 sec	1 sec	10 sec
Open Delay Night / Bank	0 %		
Crawl or Slow Open distance	10 %		
Crawl or Slow Close distance	10 %		
Open Acceleration	77 %		
Close Acceleration	50 %		
Force Setting	67 %		

1. Controller Technical Data

Line power:	Standard Appliance Plug 120V / 60 Hz
Line Fuse:	T2A (5mm x 20mm) fine wire fuse
Motor connection:	Motor GR 63x25
Position Encoder:	Connected to Motor shaft
Service Button:	Start Learn Cycle & activation signal by pressing button
Operation Signal:	LED light signal indicates operation or Learn Cycle

For the Phoenix Connector on the right side, the following pin numbers and coding apply.

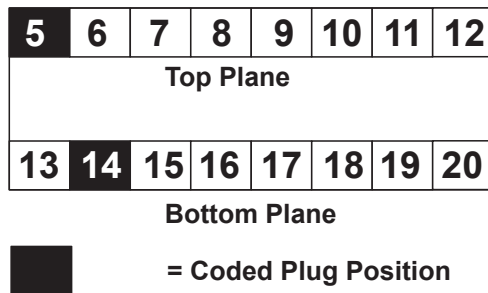

1.1 Terminal Designations

Program switch / Vestibule switch

5	GND	
6	NIGHT / BANK	- Input
7	GND	
8	Program switch: HOLD OPEN	- Input
9	Program switch: PARTIAL OPEN	- Input
10	Program switch: EXIT	- Input
11	Program switch: AUTOMATIC	- Input
12	Program switch: OFF	- Input

Special Functions, Normally Open Contacts

13	GND	
14	Vestibule	- Input
15	GND	
16	Emergency Close	- Input
17	Door Status	- output
18	Door Status	- output
19	Bell, Alarm	- output
20	Bell, Alarm	- output

Serial Port

1	GND
2	BUS A
3	BUS B
4	+24 V

Line

ESA = 120V / AC

The plugs on the left side have no additional labels, since, with the exception of the Emergency-OFF, no un-terminated cables connect here; only plug ready cables are connected.

Position Encoder

Plug, 5 pin, for connecting a position encoder.

Parallel Port

Plug, 26 pin, for connecting a flat cable.

Battery Back Up Module

Plug, 20 pin, for connecting a flat cable.

EMERGENCY-OFF

Plug, 2 pin, bridge when not in use.

Motor

Plug, 2 pin, mating plug is found on the motor cable.

Additional Plug Information

Night/Bank

- Terminals 5 & 6 - see Page 27, Item 7.

Card Reader

Activation uses the normally open circuit on the main controller, ports 5 & 6 (labeled "Night bank"). The open and close time delay occurring before & after activation can be adjust via the hand terminal (see hand terminal instructions).

Push Plate

- In lieu of motion detector, wire into ground & Radar 1, or 2, on the sensor interface board.
 - In addition to motion detectors, wire into ports 5 & 6 on main controller (labeled "Night bank"). The open & close time delay occurring before & after activation can be adjusted via the hand terminal (see hand terminal instructions).

Vestibule Input

- Terminals 13 & 14 - requires dry contact, 1.5mA load.
 - In the default mode, when a contact is closed between these terminals, the door sensors, (but not the safety beams) are ignored. If the door is closed, the door will not open in response to a signal from the sensors. If the door is open, the sensors will then be ignored and the door will close, unless a safety beam is interrupted. The door will resume closing when the safety beams are cleared. The mode of operation can be modified with the hand terminal. Further description is provided in the Hand Terminal Instructions.

Emergency Close Input

- Terminals 15 & 16 - requires dry contact, 1.5mA load.
 - This function is defaulted to OFF, and as such has no affect on normal operation. To turn ON, a hand terminal is required. In the main menu, select "4 - Door Variants", then select submenu "8 - Special Unit", and scroll down to "Panic Closing". It will indicate a setting of "0" - press "1", then "Enter", then "Break". Now, when a contact is closed between the terminal, all sensors are ignored and the door immediately closes and remains closed until the 3 position rocker switch - AUTO/OFF/ON - is turned "OFF" then back to "AUTO", and normal operation is resumed.

Door Status Output

- Terminals 17 & 18 - Normally Open dry contact, 1A @ 24V max.
 - Contacts close when door is open: remains functional when 3 position rocker switch - AUTO/OFF/ON - is in the "OFF" mode. It is not functional if 120V power is removed from the operator.

Bell, Alarm Output

- Terminals 19 & 20 - Normally Open dry contact, 1A @ 24V max.
 - Contacts close when safety beams are interrupted AND the door is open. It is not functional if AUTO/OFF/ON rocker switch is "OFF", or if 120V power is removed from the operator. Does not respond to Presence input.

Commissioning / Adjustments / Functional Test

Preparation for Commissioning

Basic Requirements

- The operator installation is complete.
- The circuit breaker is on.
- The safety beams are active.
- Those components delivered separately, such as the program switch and motion detectors, are installed and connected.
- The end stops are installed such that each sliding door panel contacts an end stop in the fully open position and when the door is fully closed, neither the fixed sidelites, nor the sliding door panels, impact the weatherstrip extrusion.

Commissioning

1. Make sure the **Program Switch** located on the jamb is in the **“Automatic”** mode with the **“Exit Only”** and **“Partial Open”** switches in the **off** position.
2. Open sliding panel(s) approximately 5” to 6”. **Note:** Single Slide door panels configured as **P-SX, O-SX** and **SX-SO** must be closed for this process, as they have reverse motor leads.
3. Plug power cord into the ESA controller.
4. Immediately, **press and hold** the black service button on the front of the controller until the door(s) begin to move. This takes approximately 25 seconds. Release the button after the door(s) start to move.
5. The controller will now go through a self-learn cycle. This self-learn process is described as follows:
 - The door will automatically close.
 - The door will “jerk” open a small distance to measure inertia.
 - It will then creep to a full open position, which also determines the stroke.
 - From here the door will close.
 - After closing, the door(s) will slightly open and close three times to test the closed position and reconfirm the start-up inertia.
 - The door has now programmed its stroke, inertia and the factory default settings.**•IMPORTANT: Do not disrupt this process! If interrupted, disconnect power, then return to Step 3 above.**
6. After the doors have completed the initialization procedure, you can then change the factory defaults by way of the Hand-Terminal.

Adjustment

The controller has default settings which are optimized for the majority of applications. If different settings are desired these are set using the Hand Terminal (HT). This procedure is explained in the instructions for the Hand Terminal.

To reestablish the default settings

Follow the instructions given above under Commissioning.

Setting the Partial Opening Width

The partial opening width can be set either by the hand terminal, or by using the rocker switch control panel. With the door fully closed and the “Partial Open” switch “OFF”, turn on the 3 position - AUTO/OFF/ON - rocker switch to “OPEN”. The door will begin opening at a slow speed. When it reaches the desired partial open position, turn the rocker switch from “OPEN” to “OFF”. Turn the Partial Open rocker switch from “ON”, then change the 3 position rocker from “OFF” to “AUTO”. The door will pause, then resume opening at a slow speed to fully open, time out, then close normally. With the Partial Open rocker switch “ON”, the door will stop at the desired position in further operation (until the switch is returned to the “OFF” position).

Functional Test

Safety Beams

While the doors are closing, interrupt each safety beam. The LED on the board, to which the safety beams are wired, will light up and the door will reverse.

With the door in the open position, interrupt each safety beam for a variable time. The door remains open as long as the beam is broken.

When the safety beam is cleared, then the door closes after a delay, which corresponds to the setting of the hold open time. An automatic test of the safety beams is executed immediately, prior to each close cycle of the door.

Activation Devices

Test all activation and safety devices in each position of the program switch. Refer to the respective installation manuals for instructions on adjusting these devices.

Emergency-Off

Normally on ESA-200 operators, the Emergency Off two-pin connector is jumpered. If an Emergency Off switch is desired, use a Normally Closed contact. When the contacts are opened, the door will immediately stop moving, and remain so, until the contacts are closed again.

Training

Once the commissioning and functional testing are completed, the owner’s manual is handed over to the key operator, or the authorized representative, and this person is appropriately trained on the operation and maintenance of the system.

Troubleshooting Guide

If the door fails to respond properly, either during commissioning, or during normal operation, first check the following:

- Is line power available?
- Is the Emergency-Off function released?
- Is the motion sensor actuation installed?
- Safety beams are clear, not interrupted, and free of dirt and debris?
- Is the door blocked by an obstacle?
- Does the door panel slide easily (track rollers, floor guides)?
- Are the safety devices in proper working order (LED-controller is on)?
- Are all external activation devices, Emergency-Off Switch, and electric locking devices properly wired?
- Are all plugs, quick connects, and connections secure?
- Is the Rocker Switch Control Panel set to the desired operating mode?

If all of the above are in order, and the problem persists, then use the Hand Terminal (HT) for further troubleshooting.

Problem	Possible Causes	Remedy
Door runs rough and uncontrolled	Plug Cable on Position Encoder	Ensure connector is properly plugged in or change the cable.
The door remains open for all positions of the program switch	Safety Beams (LS) Emergency-Off Switch	Check the safety beam function including the LED indicator using the Hand Terminal Bridge Inputs on connector. If the problem is thereby corrected, check and, if necessary, replace the Emergency-Off Switch
The door does not open when the Program Switch is in the EXIT position or the PARTIAL OPEN position.	Activation Devices (Motion Sensors) Interior / Exterior	Remove the connector for the activation devices and replace with a bridge. If this corrects the problem check the 24V power supply, if OK then check the activation device and replace if necessary.
The door does not open when the Program Switch is in the AUTOMATIC position or the HOLD OPEN position.	Emergency-Off Switch	Bridge the Inputs of the connector. If this corrects the problem replace the EMERGENCY-OFF Switch.
The door stays open (Service indicator is off)	Short Circuit*	Disconnect the controller from the line power, wait about 2 seconds, then reconnect.

***Warning! Behavior of the controller in the event of a short circuit.**

The 24 volt power supply for the motion sensors and the locking devices are short circuit protected. In the event of a short circuit, the main power supply switches off all secondary supplies and indicator lights. The main power supply does not automatically reset when the short circuit is removed. Remove the plug to the power, wait approximately 5 minutes, then reconnect the power plug.

Operation Instructions

The electro-mechanical sliding door operator can be installed with any one of the following three Program Switch types:

1. Program Panel - (Standard)
2. Mechanical Program Switch - (Optional)
3. Control Panel 90 - (Optional with separate instructions)

1.1 Program Panel

The program panel is installed in one of the vertical door jambs. The following functions can be selected using the three toggle switches:

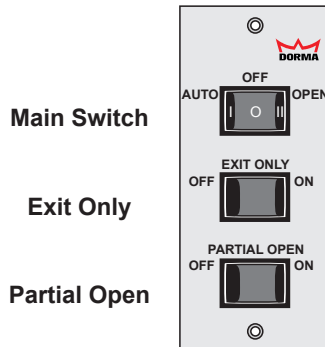

Main Switch

Switch is in position:

AUTO



When an activation signal is received at either Radar1, (assuming the EXIT ONLY switch described below is "OFF"), and/or Radar2 inputs, the door will open. After opening, signals received from the Presence input, or the Safety Beams, will cause the door to remain open, or re-open the door if received while the door is closing. After all the sensors have cleared, the hold open delay is initiated, and when it expires, the door will close.

OPEN



Continuous Open Operation
The door opens to the full opening width and remains in this position. Manual operation of the door is possible, with some resistance from the operator.

OFF



The door stops immediately when the switch is placed in this position. Manual operation of the door is possible, with some resistance from the operator.

Switch - EXIT ONLY

(Main Switch is in AUTO position)

EXIT ONLY Switch is in position:

ON



In this position, the exterior motion detector is switched off for activation, the door can only be activated from the interior motion detector (e.g. one-way traffic function after a store has closed). The exterior Radar1 is active while the door is open and cuts off in the closed position.

When an activation signal is detected from the interior (Radar2), the door opens, delays according to the hold open time setting, then closes.

If, in addition, the Partial Open Switch is

set to the ON position, the door opens only to the predetermined partial open position and closes after the expiration of the hold open delay.

OFF



The Exit Only function is switched OFF.

Switch - PARTIAL OPEN

(Main Switch is in the AUTO position)

PARTIAL OPEN Switch is in position:

ON



If the Partial Open Switch is set to the ON position, the door opens only to the predetermined partial open position and closes after the expiration of the hold open delay. If, in addition, the EXIT ONLY switch is in the ON position, then the door can be activated only from the interior devices; the exterior motion detector is switched OFF.

2. EMERGENCY OFF Switch (Optional)

When the EMERGENCY OFF Switch is depressed, the motor connection is disrupted. The door can be easily moved manually.

3. Exterior Motion Sensor

Program Switch is in position:

AUTOMATIC, or PARTIAL OPEN.

Upon detection of an activation signal from a motion sensor, the door opens and then closes after expiration of the preset hold open delay.

4. Interior Motion Sensor

Program Switch is in position:

AUTOMATIC, EXIT, or PARTIAL OPEN.

Upon detection of an activation signal from the interior motion sensor, the door opens and then closes after expiration of the preset hold open delay.

5. Presence-Sensor (Optional)

If a person, or object, is in the detection zone of the presence sensor, an activation signal is generated and the door opens and closes after the detection zone is clear, and the preset hold open delay has expired.

6. Activation Device Night / Bank (Optional - key switch or card reader)

Program Switch is in position:

AUTOMATIC, PARTIAL OPEN or EXIT

Upon detection of an activation signal from a key switch, or card reader, the door opens and then closes after expiration of the preset hold open delay.

Program Switch is in position:

OFF

Upon detection of an activation signal from a key switch, or card reader, the door opens then closes, after expiration of the preset hold open delay (maximum 10 seconds), or immediately after passing through the opening (adjustable by service technician).

7. Panic Button or Switch (Optional)

All Program Switch positions:

Upon detection of an activation signal from the button or switch, all motion and presence sensors are switched OFF and the door closes immediately.

Release the Panic Function:

Switch the Program Switch through the positions AUTOMATIC - OFF - AUTOMATIC. The panic function is released, and the operator is again in the AUTOMATIC mode.

8. Restart after power failure

When power returns, the control board starts automatically a self test due to safety reasons. (ca. 25 secs)

Finishing the test after appr. 25 secs., the door closes in slow speed and runs in the set program mode.

Attention!

The above sequence will **not** activate when the emergency button is activated, or if the main switch is OFF.

9. Safety Functions

9.1 System Safety Test

The controller performs continuous safety checks for the internal hardware (RAM, ROM, CPU).

The safety beams are automatically tested prior to each closing cycle of the door. If the test result indicates that a problem exists, the door remains in the open position. The system must then be checked and commissioned by a Service Technician.

9.2 Closing- / Opening force monitoring

If the closing door encounters an obstacle, it reverses its motion and opens to the full opening width. Then it closes at the crawl speed. This procedure is repeated until the obstacle is cleared.

If the door encounters an obstacle during the opening cycle, it stops.

After approximately 10 seconds, the door attempts another opening, but this time at the crawl speed. If an obstacle is again encountered, the door stops again.

After approximately 6 attempts, the door closes. At the next opening cycle, the door opens normally to just before the obstacle position, then continues opening at the crawl speed. If the obstacle is still present, the door closes immediately. When the obstacle is cleared, the door opens to the full opening width and assumes its normal operation function.

9.3 Safety Beams / Presence-Sensor (Optional)

The threshold area between the open door panels is monitored by the safety beams and optionally by a presence sensor. If a person, or obstacle, is detected in this area, during the closing cycle of the door, the door reverses and then opens to the full opening width and remains in this position. When the threshold area is again clear, and the preset hold open delay has expired, the door closes. For the Program Switch settings, except OFF, and with the door in the closed position, the door will NOT open upon detection of an activation signal from the safety beams, or from the presence sensor.

10. Care and Maintenance

Prior to first use and periodically thereafter, but at least once a year, the system must be checked and maintained by a qualified, knowledgeable technician.

During the cleaning operation, the Program Switch must be either in the OFF, or HOLD OPEN position to avoid automatic movements of the door panels.

Disconnect the line power cord before servicing.

The entire sliding door assembly (Aluminum, Glass, Covers) can be cleaned with a moist towel and common commercial non abrasive cleaners. The safety beams are to be cleaned with a dry, soft, non abrasive towel.

The floor area near the sliding door panels, including the threshold, must be kept clean.

11. Troubleshooting of Problems

If the door does not open, or close, check the following:

- Is the line power connected and active?
- Is the EMERGENCY-OFF released?
- Is the Program Switch in the proper position?
- Is the safety beam path clear and clean?
- Is the door blocked by obstacles?

If all of the above checks out OK call a qualified Service Technician.